

NV700

Continuous motion bundler with shrink-wrapping

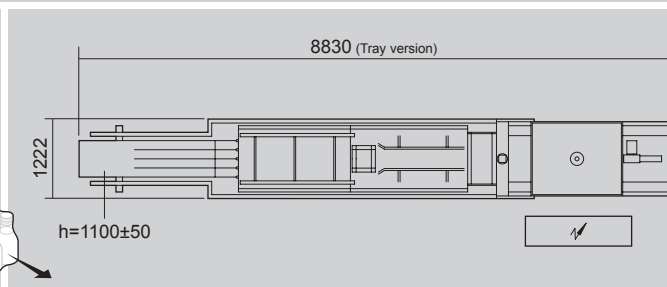
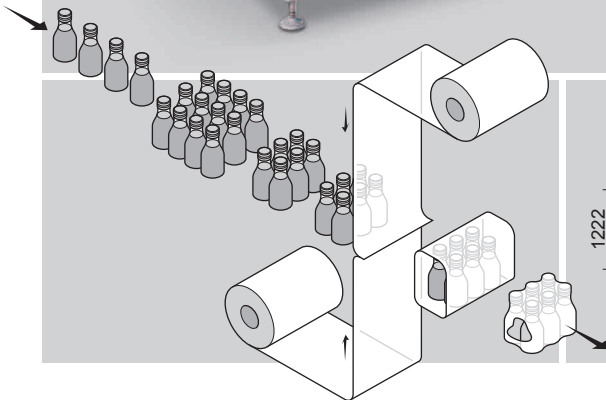

TECHNICAL DATA

Mechanical speed	STROKES/1'	max. 25
Power absorption	KW	13
Air consumption	NI/1'	7
Air pressure	bar	6
Gross weight	kg	~2200
Net weight	kg	~2000
Size range		
	min.	max.
d_i	100	380
e_i	200	480
f_i	50	360
H	30	80
d_i+e_i	-	680
d_i+H	280	560
f_i+H	130	440

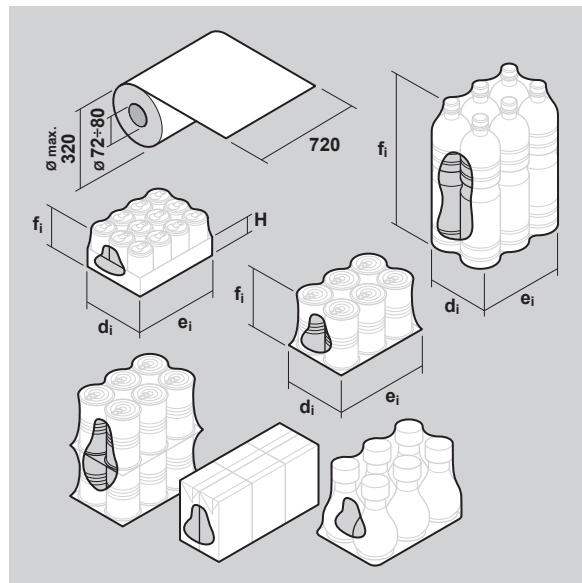

The above technical data are not binding and may be subject to change without prior notice.

CM-008-uk (12/11/2014)
Extr. from FM-NV700-02-uk (10/11/2014)

This publication supersedes and replaces any previous edition and revision. All rights reserved. No part of this publication may be reproduced, stored in a retrieval system or transmitted in any form or by any means, electronic, mechanical, photocopying, recording or otherwise, without permission of Tecnicam s.r.l. (Bologna - Italy).