

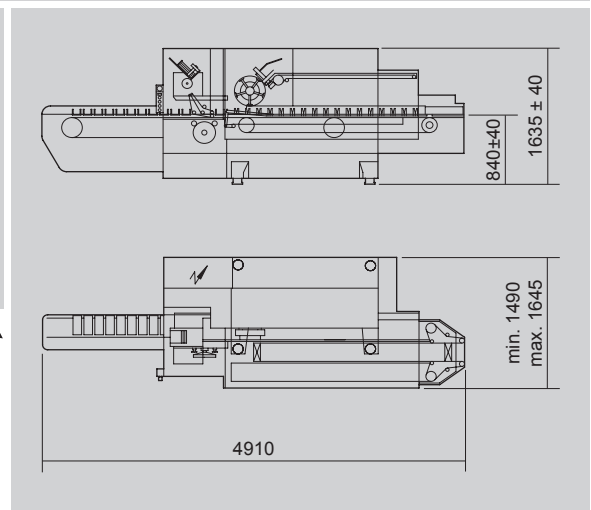

HV

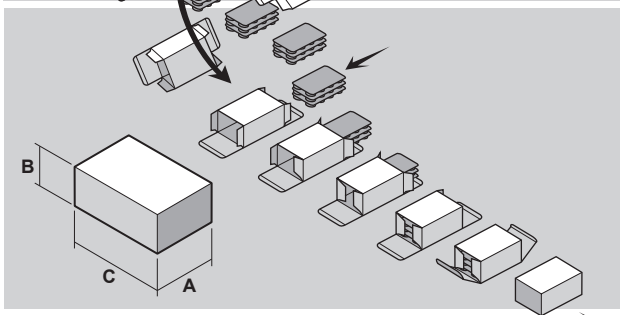

High speed continuous motion horizontal cartoner



TECHNICAL DATA		HV 1	HV 2
Mechanical speed	STROKES/1'	max. 400	max. 260
Motors	KW	4.25	4.25
Power absorption	KW	5.20	5.20
		(Hot-melt + 3.9)	(Hot-melt + 3.9)
Air consumption	NI/1'	16.9	16.9
Air pressure	bar	5÷6	5÷6
Gross weight	kg	~3000	~3000
Net weight	kg	~2500	~2500

Size range	HV 1	min.	max.	HV 2	min.	max.
A		20	95		20	160
B		12	70		12	70
C		70	230		70	230
A + B		-	165		-	200

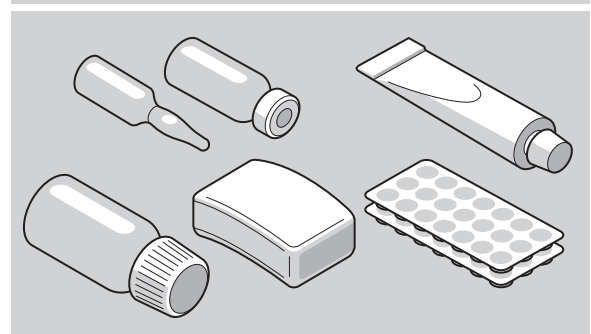

The above technical data are not binding and may be subject to change without prior notice.

CM-008-uk (12/11/2014)
Extr. from FM-HV-02-uk (10/11/2014)

This publication supersedes and replaces any previous edition and revision. All rights reserved. No part of this publication may be reproduced, stored in a retrieval system or transmitted in any form or by any means, electronic, mechanical, photocopying, recording or otherwise, without permission of Tecnicam s.r.l. (Bologna - Italy).