

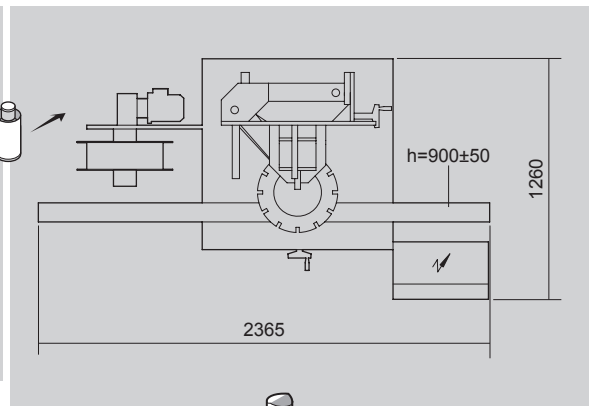

SL4000

Alternate motion shrink-sleeve application machine

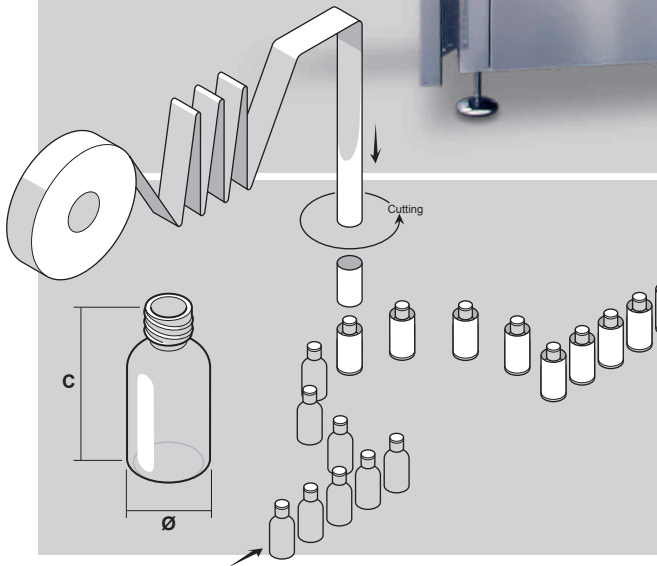
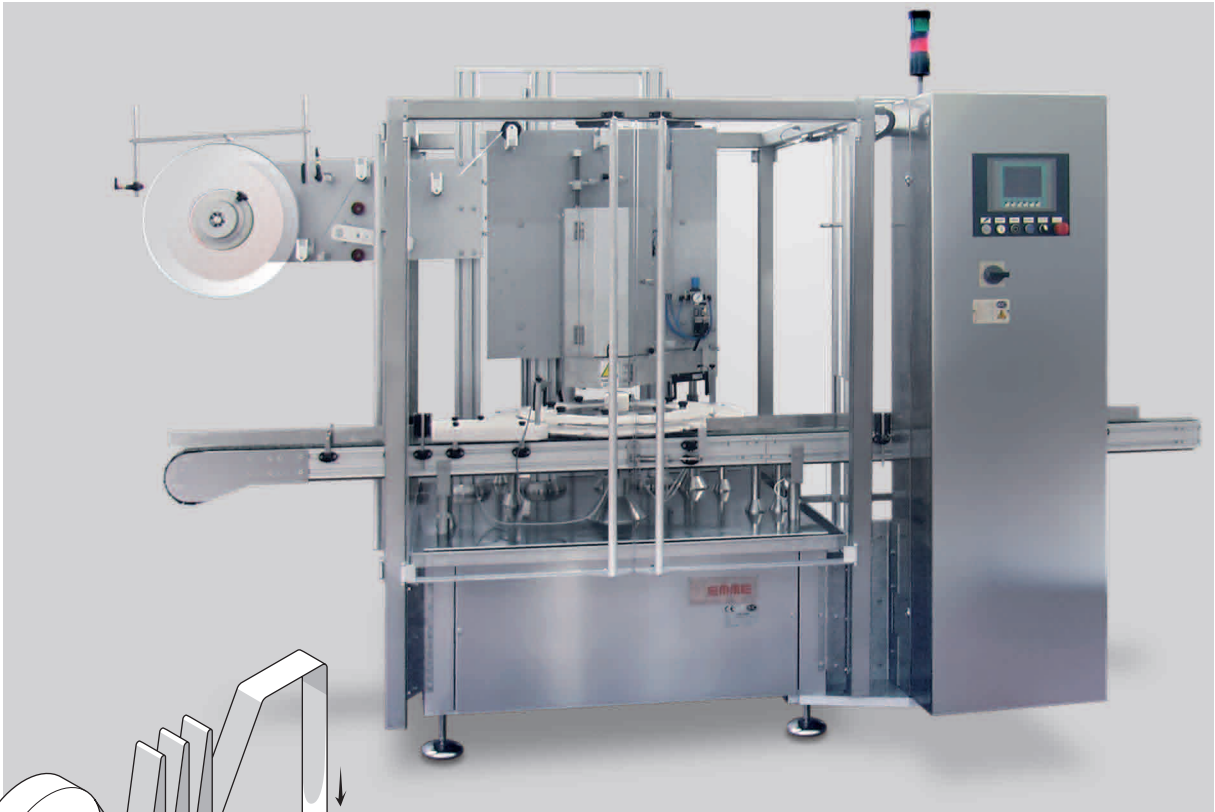

TECHNICAL DATA

Mechanical speed	STROKES/1'	67
Power absorption	KW	1.1
Size range	min.	max.
Ø	25	100
c	30	300

The above technical data are not binding and may be subject to change without prior notice.

CM-008-uk (12/11/2014)
Extr. from FM-SL4000-02-uk (10/11/2014)

This publication supersedes and replaces any previous edition and revision. All rights reserved. No part of this publication may be reproduced, stored in a retrieval system or transmitted in any form or by any means, electronic, mechanical, photocopying, recording or otherwise, without permission of Tecnicam s.r.l. (Bologna - Italy).