

# PVX

## High speed intermittent motion horizontal cartoner

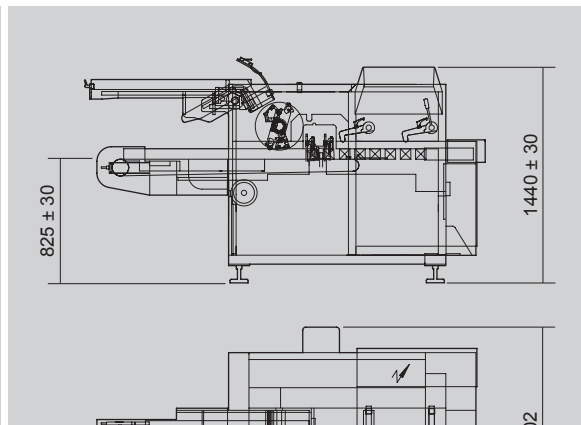
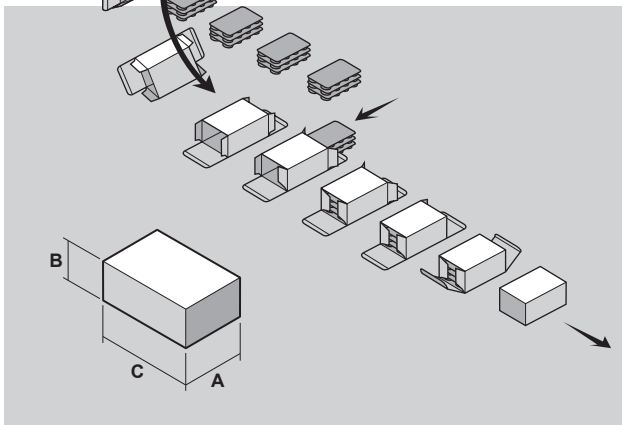
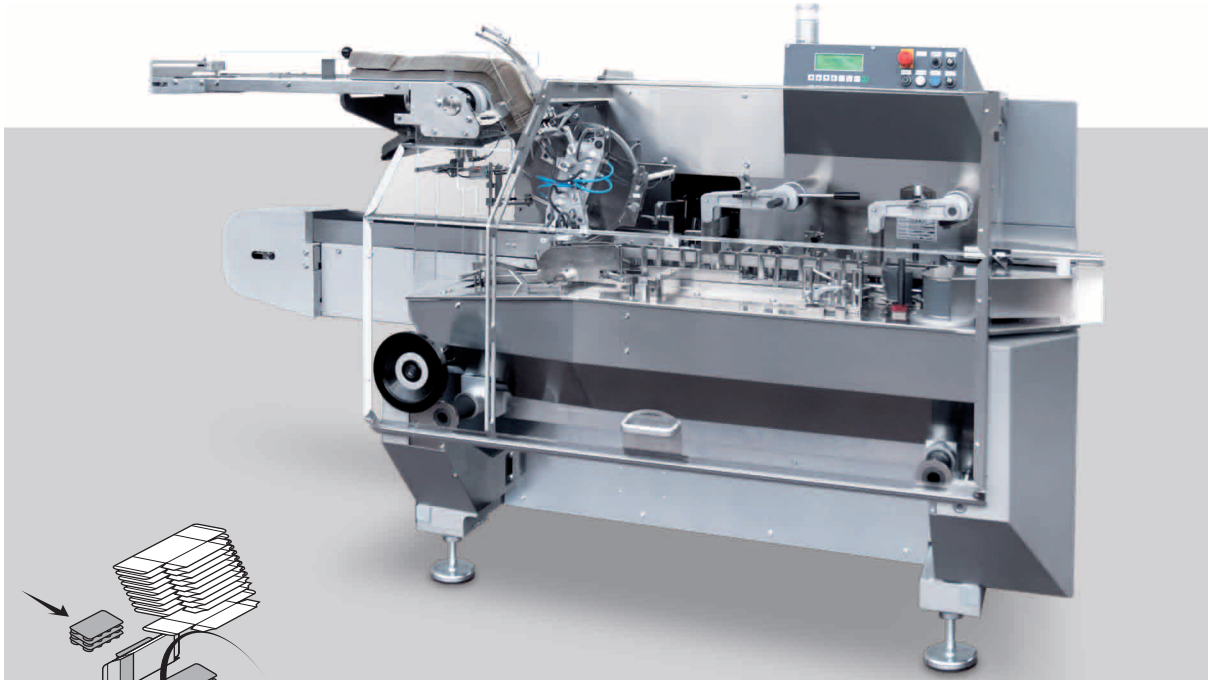

### TECHNICAL DATA

Mechanical speed	<b>STROKES/1'</b>	250
Power absorption	<b>KW</b>	2.1 (Hot-melt + 3.9)
Air consumption	<b>NI/1'</b>	16.9
Air pressure	<b>bar</b>	5÷6
Gross weight	<b>kg</b>	~1400
Net weight	<b>kg</b>	~1230
<hr/>		
Size range	<b>min.</b>	<b>max.</b>
<b>A</b>	15	80
<b>B</b>	12	75
<b>C</b>	65	160
<b>A + B</b>	-	155

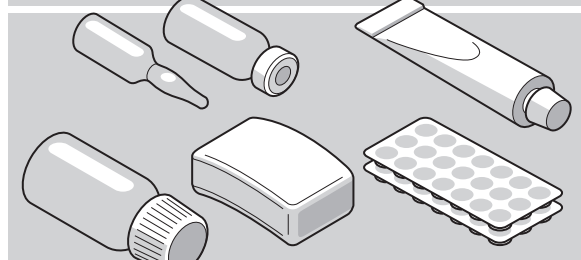
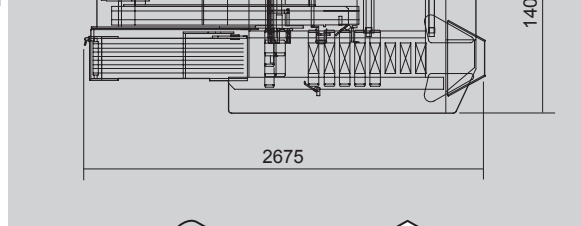

The above technical data are not binding and may be subject to change without prior notice.

CM-008-uk (12/11/2014)  
Extr. from FM-PVX-02-uk (10/11/2014)

This publication supersedes and replaces any previous edition and revision. All rights reserved. No part of this publication may be reproduced, stored in a retrieval system or transmitted in any form or by any means, electronic, mechanical, photocopying, recording or otherwise, without permission of Tecnicam s.r.l. (Bologna - Italy).