

nMX-C

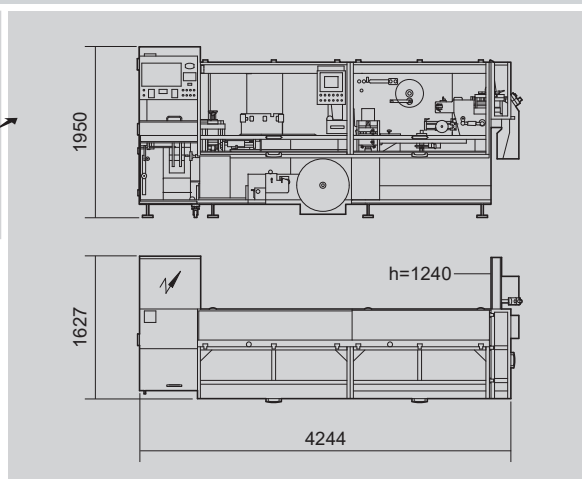

New compact automatic high speed blister packaging machine with plate sealing

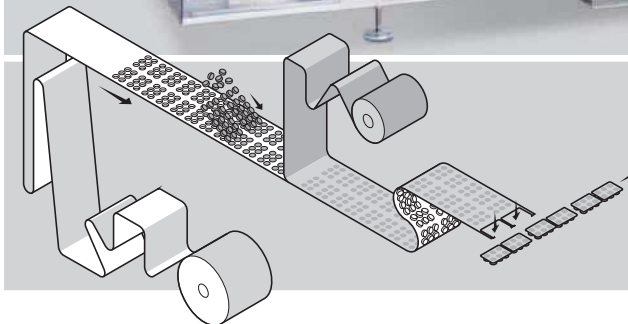

TECHNICAL DATA

Production up to	BLISTERS/1'	540
Mechanical speed	STROKES/1'	16+50
Power absorption (max.)	KW	15
Air consumption	NI/1'	500
Air pressure	bar	6
Gross weight	kg	~3500
Net weight	kg	~3200

Size range	min.	max.
L Web width (mm)	90	286
P Stroke length (mm)	70	204
A Blister width (mm)	30	85
B Forming depth (mm)	3	12
C Blister length (mm)	60	120
F Blister rows across the web	1	3
Blister rows along the pitch (N)	1	4
Number of blisters per cycle (G)	1	12

Forming materials PVC; PVC+PVDC; TRIPLEX; COC; ACLAR; ALU

The above technical data are not binding and may be subject to change without prior notice.

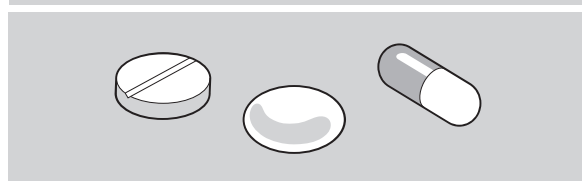
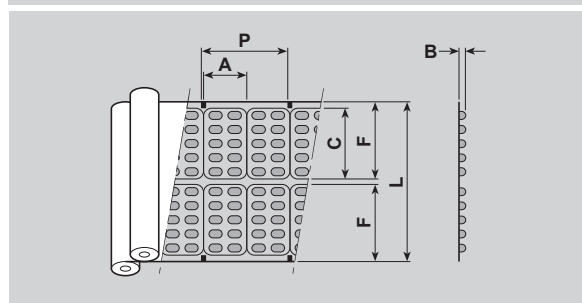

CM-011-uk (20/03/2017)
Extr. from FM-nMXC-02-uk (14/03/2017)

This publication supersedes and replaces any previous edition and revision. All rights reserved. No part of this publication may be reproduced, stored in a retrieval system or transmitted in any form or by any means, electronic, mechanical, photocopying, recording or otherwise, without permission of Tecnicam s.r.l. (Bologna - Italy).