

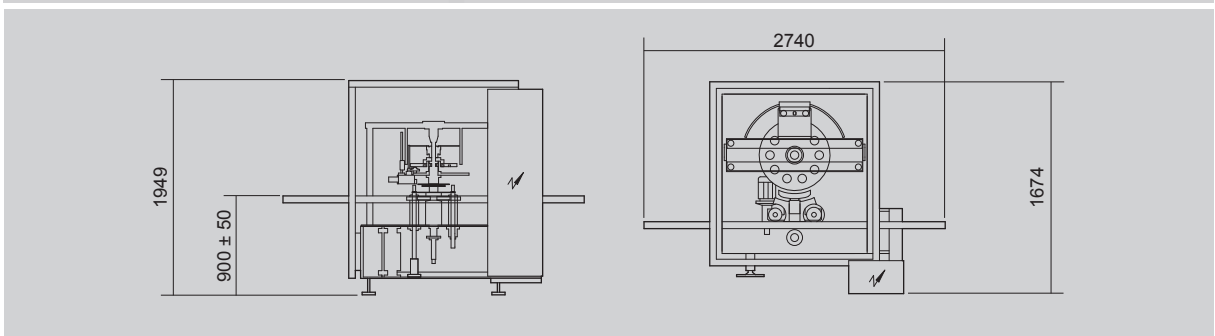

MT32

Testing machine for spray cans

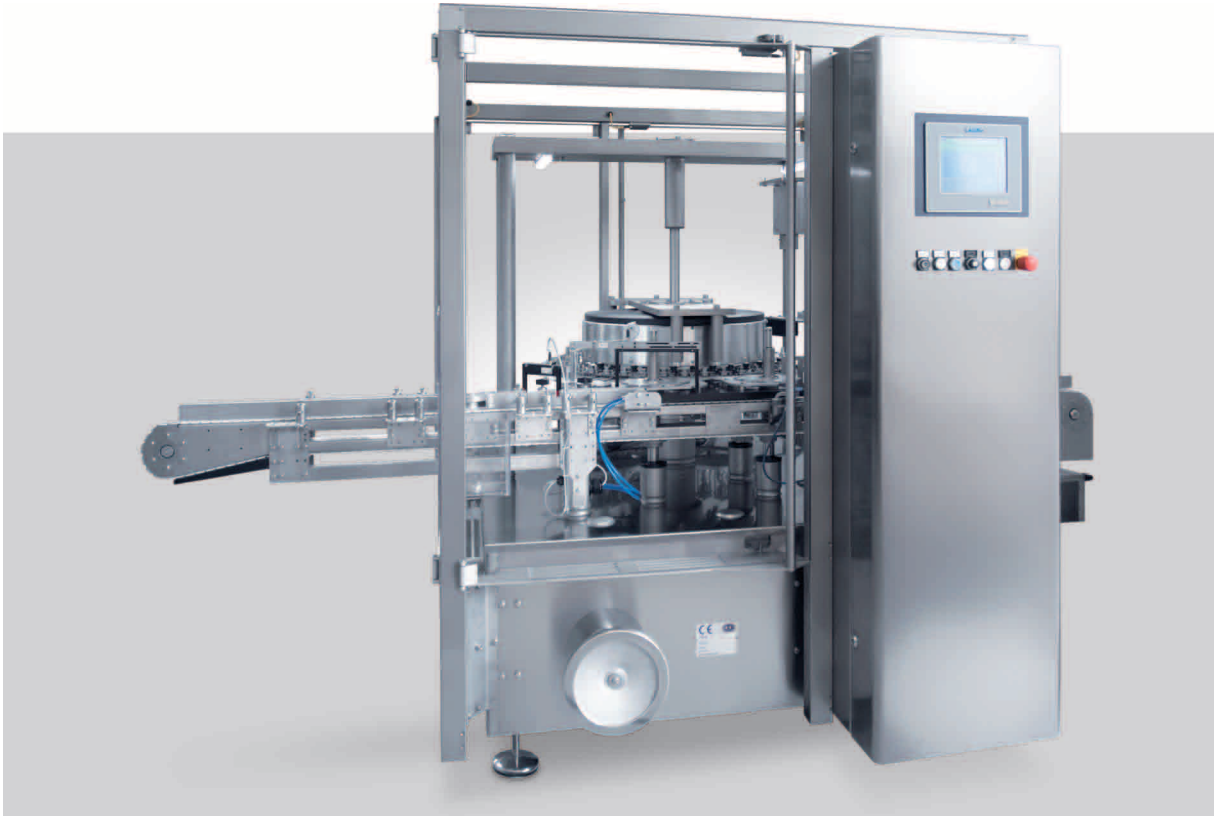

TECHNICAL DATA

Mechanical speed	STROKES/1'	300
Motors	KW	2.2
Power absorption	KW	3
Air consumption	NI/1'	16.6
Air pressure	bar	5+6
Gross weight	kg	~1900
Net weight	kg	~1900
<hr/>		
Size range	min.	max.
Ø	20	27
C	45	75

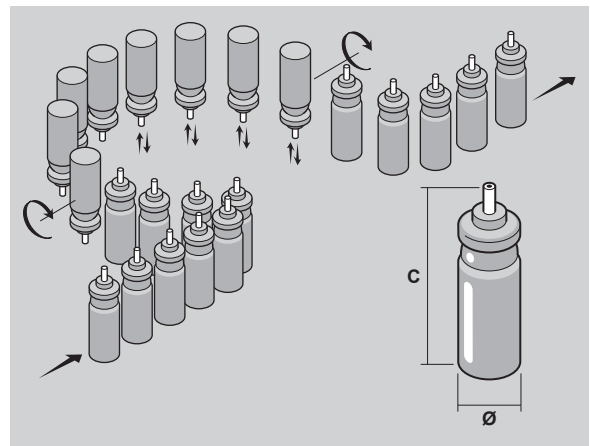

The above technical data are not binding and may be subject to change without prior notice.

CM-008-uk (12/11/2014)
Extr. from FM-MT32-02-uk (10/11/2014)

This publication supersedes and replaces any previous edition and revision. All rights reserved. No part of this publication may be reproduced, stored in a retrieval system or transmitted in any form or by any means, electronic, mechanical, photocopying, recording or otherwise, without permission of Tecnicam s.r.l. (Bologna - Italy).