

# KG

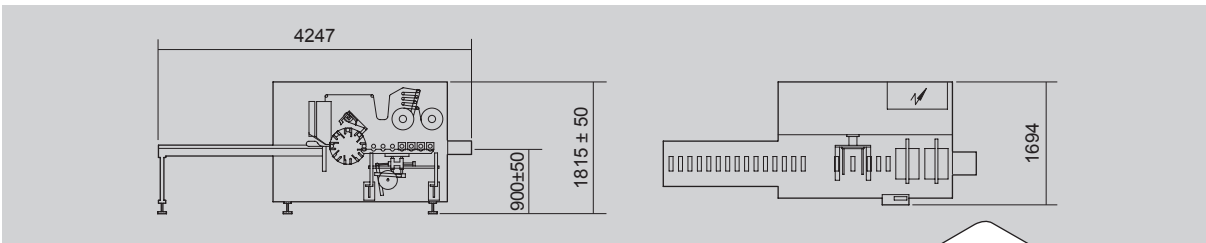

## Overwrapper for biscuits by X-fold or hermetic sealing



### TECHNICAL DATA

Mechanical speed	<b>STROKES/1'</b>	90
Power absorption	<b>KW</b>	8
Air consumption	<b>NI/1'</b>	17
Air pressure	<b>bar</b>	6
Gross weight	<b>kg</b>	~4100
Net weight	<b>kg</b>	~3600

Size range	min.	max.
<b>A</b>	40	100
<b>B</b>	40	85
<b>Ø</b>	40	85
<b>C</b>	100	340
<b>F</b>	120	420
<b>G</b>	150	400
<b>B + C</b>	-	380

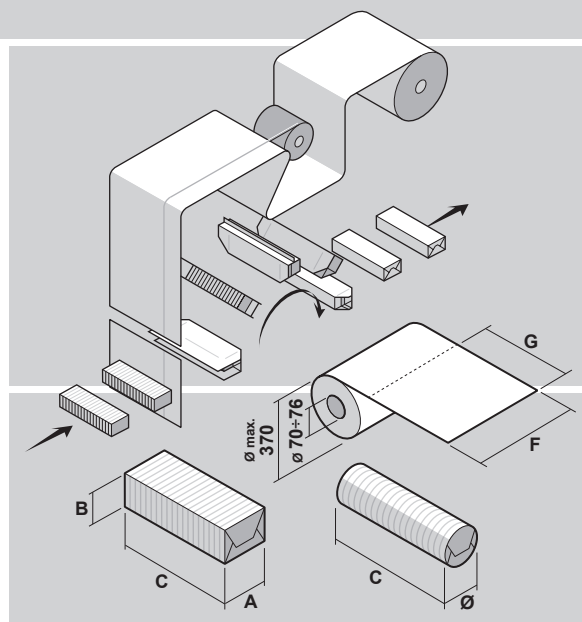

The above technical data are not binding and may be subject to change without prior notice.

CM-008-uk (12/11/2014)  
Extr. from FM-KG-02-uk (10/11/2014)

This publication supersedes and replaces any previous edition and revision. All rights reserved. No part of this publication may be reproduced, stored in a retrieval system or transmitted in any form or by any means, electronic, mechanical, photocopying, recording or otherwise, without permission of Tecnicam s.r.l. (Bologna - Italy).