

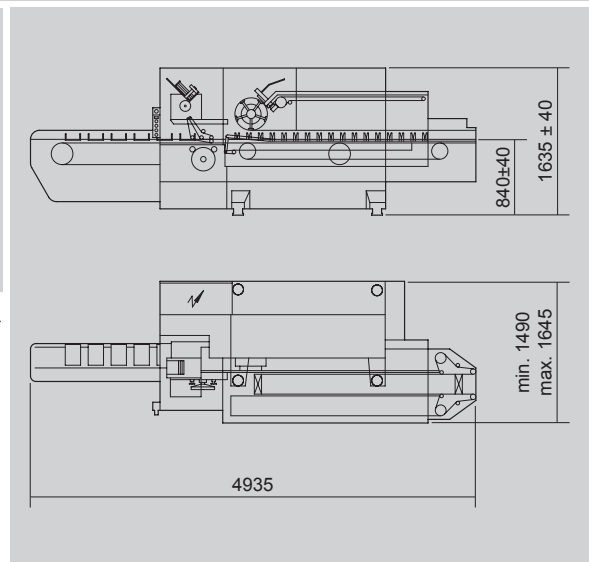

HG

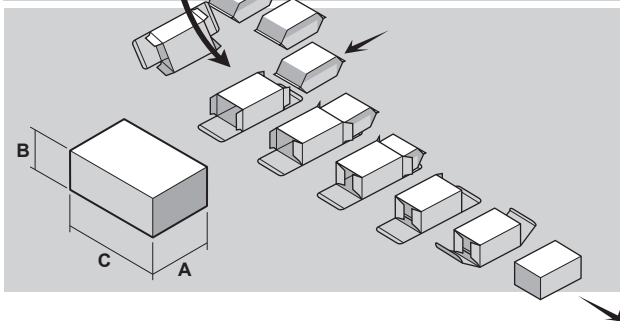

High speed continuous motion horizontal cartoner for large size products

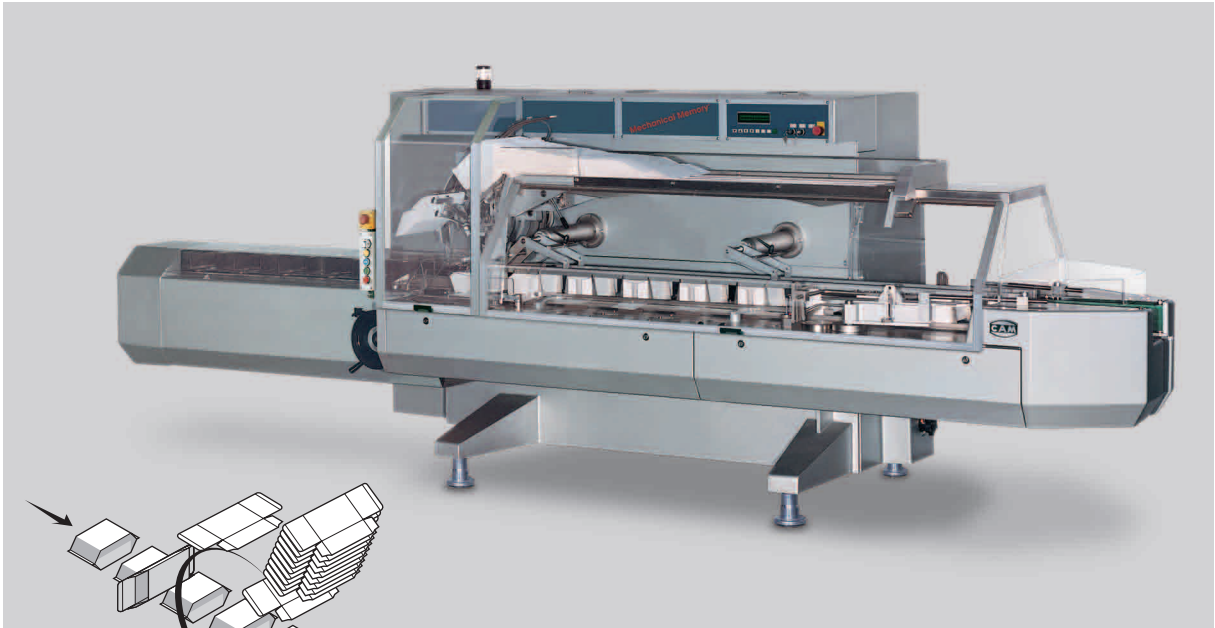

TECHNICAL DATA

Mechanical speed	STROKES/1'	max. 200
Motors	KW	4.25
Power absorption	KW	5.20 (Hot-melt + 3.9)
Air consumption	NI/1'	16.9
Air pressure	bar	5+6
Gross weight	kg	~3100
Net weight	kg	~2600
Size range	min.	max.
A	50	200
B (Tuck-in)	30	70
B (Hot melt)	30	100
C	70	230
A+B	-	230

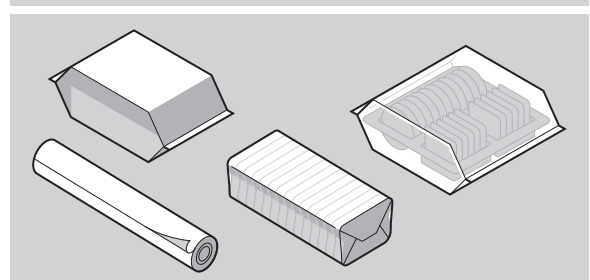

The above technical data are not binding and may be subject to change without prior notice.

CM-008-uk (12/11/2014)
Extr. from FM-HG-02-uk (10/11/2014)

This publication supersedes and replaces any previous edition and revision. All rights reserved. No part of this publication may be reproduced, stored in a retrieval system or transmitted in any form or by any means, electronic, mechanical, photocopying, recording or otherwise, without permission of Tecnicam s.r.l. (Bologna - Italy).