

# 5000/90

## Strip packaging vertical machine

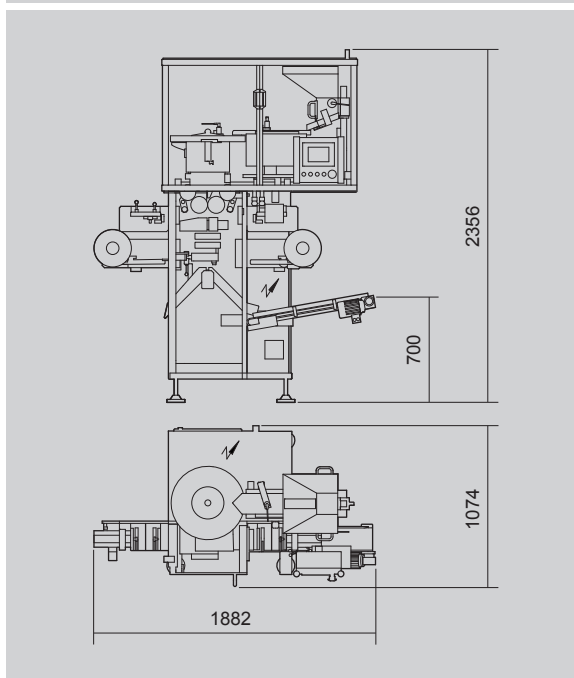
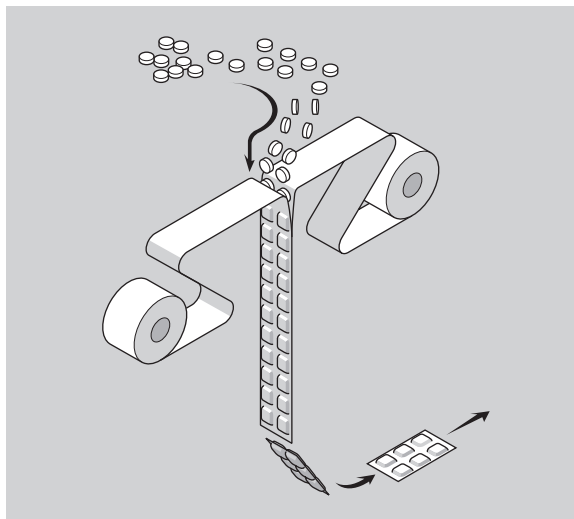

### TECHNICAL DATA

Mechanical speed	<b>STROKES/1'</b>	250 (Depending on package size)
Power absorption (max.)	<b>KW</b>	5.5
Air consumption	<b>NI/1'</b>	120
Air pressure	<b>bar</b>	6
Gross weight	<b>kg</b>	~800
Size range	<b>min.</b>	<b>max.</b>
<b>A</b>	20	110
<b>C</b>	20	Programmable
<b>L (Reel width)</b>	-	110

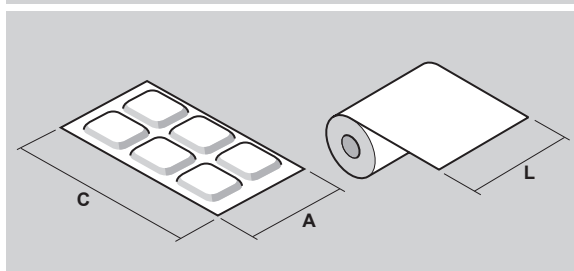

The above technical data are not binding and may be subject to change without prior notice.

CM-008-uk (12/11/2014)  
Extr. from FM-500090-02-uk (10/11/2014)

This publication supersedes and replaces any previous edition and revision. All rights reserved. No part of this publication may be reproduced, stored in a retrieval system or transmitted in any form or by any means, electronic, mechanical, photocopying, recording or otherwise, without permission of Tecnicam s.r.l. (Bologna - Italy).